

EB-E36-LP

GPS Module User's Guide

**Date: Nov, 2006
Version: 1.0**

All Rights Reserved



Manual Revision History

| Revision | Date | Update Summary |
|-----------------|-------------|-----------------------|
| Issue A | Nov, 2006 | Initial release |
| | | |
| | | |

© EverMore Technology Inc. All rights reserved.

Not to be reproduced in whole or part for any purpose without written permission of EverMore Technology Inc. Information provided by EverMore Technology Inc. is believed to be accurate and reliable. However, no responsibility is assumed by EverMore Technology Inc. for its use. EverMore Technology Inc. reserves the right to change specification at any time without notice.



| | |
|---|----------|
| 1 INTRODUCTION | 4 |
| 1.1 OVERVIEW | 4 |
| 1.2 FEATURES | 4 |
| 1.3 APPLICATIONS | 4 |
| 2 RECEIVER OPERATION | 5 |
| 2.1 EB-E36-LP GPS MODULE SPECIFICATION | 6 |
| 2.2 START-UP MODES | 7 |
| 3 HARDWARE INTERFACE..... | 8 |
| 3.1 EB-E36-LP SYSTEM BLOCK DIAGRAM | 8 |
| 3.2 EB-E36-LP REAL PICTURE..... | 11 |
| 3.3 ANTENNA CONNECTOR..... | 11 |
| 3.4 INTERFACE CONNECTOR TYPE..... | 11 |
| 3.5 MECHANICAL DIMENSIONS AND INTERFACE CONNECTOR | 12 |
| 3.6 INTERFACE CONNECTOR PIN OUT | 13 |
| 3.6.1 Pin Header Connector JP2 16-Pin Header | 13 |
| 3.6.2 Pin Header Connector JP2 10-Pin Header | 14 |
| 3.7 ONE-PULSE-PER-SECOND OUTPUT | 15 |
| 3.8 RTCM DIFFERENTIAL DATA | 15 |



1 Introduction

1.1 Overview

The EB-E36-LP GPS Receiver is intended for use in a wide range of applications. The receiver simultaneously tracks up to twelve satellites, provides accurate satellite positioning data with fast time-to-first-fix (TTFF) and low power consumption. It is designed for high performance and maximum flexibility in a wide range of applications including mobile asset tracking, in-vehicle automotive guidance, location sensing, telematics and so on. The highly integrated receiver achieves high performance, minimizes board size and power consumption requirements. The EB-E36-LP is designed to withstand harsh operating environments; however, it should be used inside an enclosure as a part of the application product designed by the system integrator.

1.2 Features

The EB-E36-LP GPS receiver offers following features:

- **EverMore Chipset 12 Channels all in view tracking**
- **Ultra Low Power Consumption 14 mA**
- **High Sensitivity -143 dBm**
- **DGPS : WAAS/EGNOS**
- **Support Standard NMEA-0183 at 4800 bps baud rate**
- **Support 1PPS output**
- **Lead Free , RoHS Compliant**

1.3 Applications:

- **Land/Marine Navigation**
- **Telematics**
- **Fleet Management**
- **Asset Tracking**
- **Timing Reference**



2 Receiver Operation

Upon power up, after initial self-test has completed, the EB-E36-LP will begin satellite acquisition and tracking process. Under normal open-sky condition, position-fix can be achieved within approximately 45 seconds (within 15 seconds if valid ephemeris data is already collected from recent use). After receiver position has been calculated, valid position, velocity and time information are transmitted through the on board serial interface.

The receiver uses the latest stored position, satellite data, and current RTC time to achieve rapid GPS signal acquisition and fast TTFF. If the receiver is transported over a large distance across the globe, cold-start automatic-locate sequence is invoked. The first position fix may take up to five minutes searching the sky for the GPS signal. The acquisition performance can be improved significantly if the host initializes the receiver with a rough estimate of time and user position.

As soon as GPS signal is acquired and tracked, the EB-E36-LP will transmit valid navigation information through its serial interface. The navigation data contains following information:

- Receiver position in latitude, longitude, and altitude
- Receiver velocity
- Time
- DOP error-magnification factor
- GPS signal tracking status

The EB-E36-LP will perform 3D navigation when four or more satellites are tracked. When three or fewer satellites are tracked, altitude-hold is enabled using the last computed altitude and 2D navigation mode is entered.

With signal blockage or rising and setting of the satellites, where a change in satellite constellation used for position fix occurred, large position error may result. The EB-E36-LP incorporates a proprietary algorithm to compensate the effect of satellite constellation change, and maintains an accurate smooth estimate of the receiver's position, velocity, and heading.



2.1 EB-E36-LP GPS Module Specification

| ITEMS | DESCRIPTION |
|------------------------------|---|
| General | L1 1575.42MHz, C/A code, 12-channel, Carrier-Aided with HWTrack© |
| Sensitivity | -143 dBm minimum |
| Update Rate | 1Hz |
| Accuracy | Position: 15m CEP without S/A Velocity: 0.1 m/sec without S/A Time: $\pm 1\mu\text{s}$ |
| DGPS/WAAS Accuracy | Position: 5m CEP Velocity: 0.05 m/sec |
| Acquisition | Cold start: 60sec (average) Warm start: 45sec (average) Hot start: 15sec (average) |
| Reacquisition | 0.1 sec |
| Dynamics | Altitude: 18,000m Velocity: 500 m/sec Acceleration: $\pm 4\text{g}$ |
| Time Mark 1PPS | Output 1 Pulse/Sec, The rising edge of the output pulse is accurate to $\pm 1\mu\text{sec}$ with respect to the start of each GPS second. |
| Operation Temperature | -30°C to $+80^{\circ}\text{C}$ |
| Storage Temperature | -40°C to $+90^{\circ}\text{C}$ |
| Operating Humidity | 5% to 95% |
| Primary Power | 3.3Vdc, $\pm 0.1\text{Vp-p}$ ripple |
| Power Consumption | 14 mA |
| Serial Interface | Port 1: NMEA 0183 Output, Port 2: RTCM Input |
| Protocol | EverMore Private @ 4800/9600 baud, 8-None-1 NMEA-0183 v2.20 @ 4800 baud, 8-None-1 |
| Datum | 219 standard datum, default WGS-84 |
| DGPS | WAAS/EGNOS |
| Antenna | MMCX / HFL Jack for external active antenna |
| NMEA Message | Default : GGA,GSA, GSV, RMC |
| Dimension; Weight | 45mm x 31 mm x 5 mm (1.77" L x 1.22" W x 0.20" H) |
| Weight | 8g (0.28oz) |

2.2 Start-up Modes

| Definitions | DESCRIPTION |
|----------------------|---|
| Cold Start | <p>The Cold Start takes the longest startup time among EMT GPS receivers. In this scenario, the receiver has no acknowledgment on the last position, time, and satellite constellation. The receiver is initiated to search blindly for satellite signals in the cold start mode.</p> <p>Another situation is that when no backup battery is connected, the GPS receiver will be in the cold start mode and there is no data stored in SRAM.</p> <p>Execute cold start of the test tool when first use. By this way can speed up position fix time.</p> |
| Warm Start | <p>In this scenario, the receiver was off less than one week but more than 2-hour time.</p> <p>The receiver knows its last position, time and almanac because it has a backup battery to keep current almanac, position and time stored in SRAM. In the warm start mode, the receiver can quickly acquire satellites and get a position fix faster than it does in the cold start mode.</p> |
| Hot Start | <p>In this scenario, the receiver was off less than 2-hour time. With the back up battery connected and the current almanac, position, time and ephemeris stored in SRAM, the receiver applies its last ephemeris data to calculate and get a position fix.</p> |
| Reacquisition | <p>In the reacquisition mode, the receiver takes time to lock on satellites if buildings or obstacles are blocking the signals for a short while.</p> <p>This is very common in urban areas, but please be noted that reacquisition time has nothing to do with the time-to-first-fix (TTFF).</p> |

3 Hardware Interface

3.1 EB-E36-LP System Block Diagram

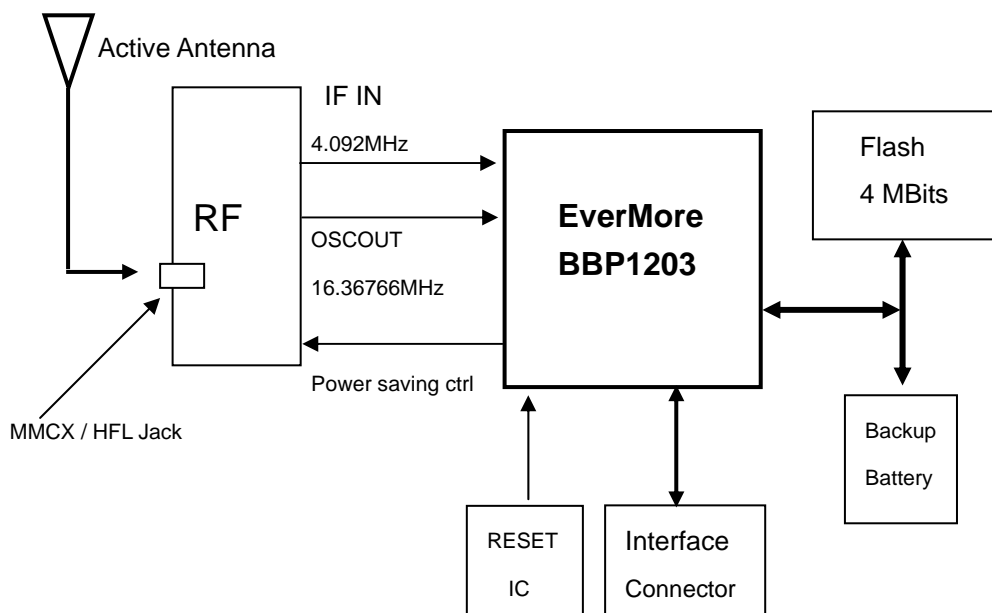

Figure 1: System Block Diagram for EB-E36-LP

Outline:

The GPS receiver completes signal processing that starts from antenna gains to serial output, and the above diagram illustrates such process. With at least four satellites, the receiver can evaluate satellite signals to determine a three-dimensional position fix by calculating longitude, latitude, height, time, speed, and acceleration. The GPS receiver provides information of the satellite constellation, satellite status, the number of visible satellites, etc.

RF:

The RF amplifier acts like the mixer, the A/D converter, and the producer of 16.367667MHz reference oscillator that offers the necessary carrier wave for frequency conversion. The analogue intermediate frequency is converted into digital format by means of a 1-bit ADC.

BBP1203 Base Band Functions:

The BBP1204 Base Band performs the following functions:

1. Processes IF 4.124MHz signal
2. Provides 12 parallel satellite channels that can be shut down individually
3. Built-in carrier/code close-loop control
4. Built-in RTC with timeout interrupt
5. Buffered demodulated data bits
6. 1pps output
7. CPU and I/O interface

BBP1203 Processor Functions:

The BBP1203 processor performs the following functions:

1. Calculating longitude, latitude, height, speed and acceleration to figure out position
2. Storing the above data to SRAM
3. Initiating and configuring the whole system
4. Executing the firmware installed
5. Converting NMEA-0183 code into proprietary EMT binary code

Flash:

The Flash stores firmware that allows the system to run automatically. The Flash also allows users to update with newer firmware versions via specific application programs.

Backup Battery:

The Backup Battery supplies SRAM with data retention current and voltage to store GPS data. Being button like, the battery also supplies real time clock power. With the rechargeable lithium backup battery, the time-to-first-fix (TTFF) can be reduced.

RESET IC:

The Reset IC sends a “reset” signal to initiate the processor.



Interface Connector:

Interface connector provides input power that includes VCC, battery and antenna power. The connector also provides RXD, TXD, 1PPS and LED digital signals.

MMCX / HFL Jack:

The MMCX / HFL Jack is a connector for external active antenna.

3.2 EB-E36-LP TOP View Picture

Figure 1 :



3.3 Antenna Connector

The RF connector is a 50 ohm straight MMCX / HFL snap-on coaxial RF jack receptacle.

3.4 Interface Connector Type

There are three interface connectors, the first is a 16-pin golden finger, and the second is a 10-pin header.

3.5 Mechanical Dimensions and Interface Connector

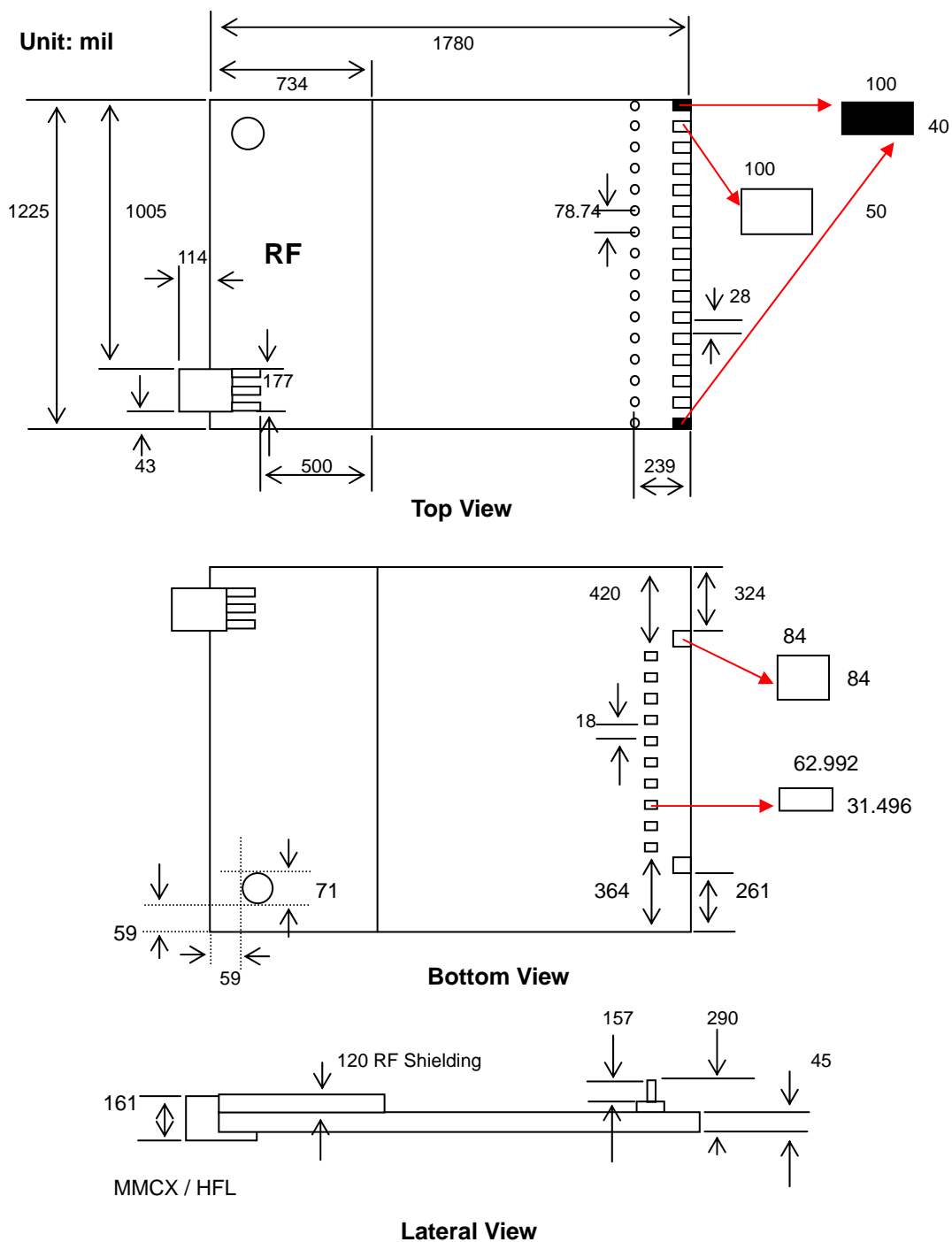

Figure 4

3.6 Interface Connector Pin Out

3.6.1 Pin Header Connector JP2 16-Pin Header

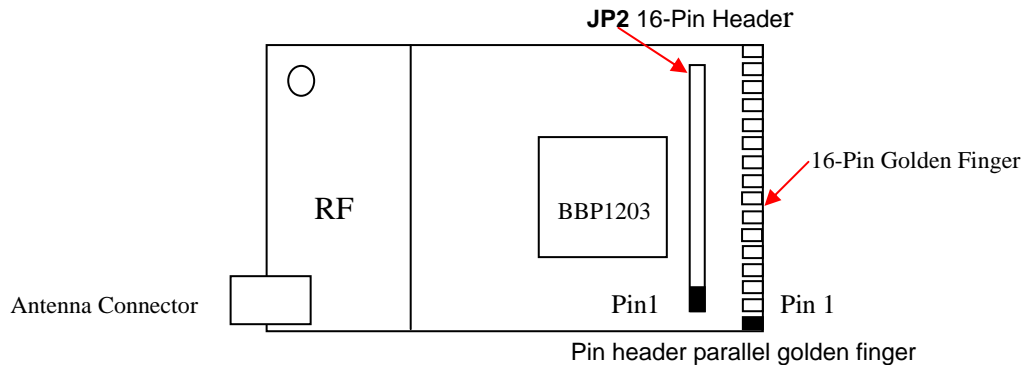

Figure 6

| Pin | Function | Input/Output | Level | Pin | Function | Input/Output | Level |
|-----|----------|--------------|--------|-----|----------|--------------|--------|
| 1 | PIO1 | In/Out | LVTTTL | 2 | PIO10 | In/Out | LVTTTL |
| 3 | PIO11 | In/Out | LVTTTL | 4 | TXD0 | Output | LVTTTL |
| 5 | RXD0 | Input | LVTTTL | 6 | PWR_IN | Input | 3.3V |
| 7 | GND | Ground | 0V | 8 | LED0 | In/Out | LVTTTL |
| 9 | 1PPS | Output | LVTTTL | 10 | TXD1 | Output | LVTTTL |
| 11 | RXD1 | Input | LVTTTL | 12 | VBAT | Input | 3.3V |
| 13 | ANT PWR | Input | | 14 | PIO12 | In/Out | LVTTTL |
| 15 | PIO13 | In/Out | LVTTTL | 16 | PIO14 | In/Out | LVTTTL |

The following is a functional description of the pins on the 16-pin interface connector.

- Pin 1. PIO1: Reserved I/O port 1 from CPU
- Pin 2. PIO10: Reserved I/O port 10 from CPU
- Pin 3. PIO11: Reserved I/O port 11 from CPU
- Pin 4. TXD0: Serial port output # 1 (GPS navigation output)
- Pin 5. RXD0: Serial port input # 1 (command input)
- Pin 6. PWR_IN: Power supply input, regulated 3.3V
- Pin 7. GND: Ground
- Pin 8. LED0: Reserved I/O port 31 from CPU
- Pin 9. 1PPS: 1-pulse-per-second output.
- Pin 10. TXD1: Serial port output #2 (currently unused)
- Pin 11. RXD1: Serial port input #2 (DGPS input)
- Pin 12. VBAT: External backup battery charging input
- Pin 13. ANT PWR: External active antenna power input
- Pin 14. PIO12: Either Reserved I/O port 12 from CPU or INT5

Pin 15. PIO13: Either Reserved I/O port 13 from CPU or INT6

Pin 16. PIO14: Reserved I/O port 14 from CPU

3.6.2 Pin Header Connector JP2 10-Pin Header

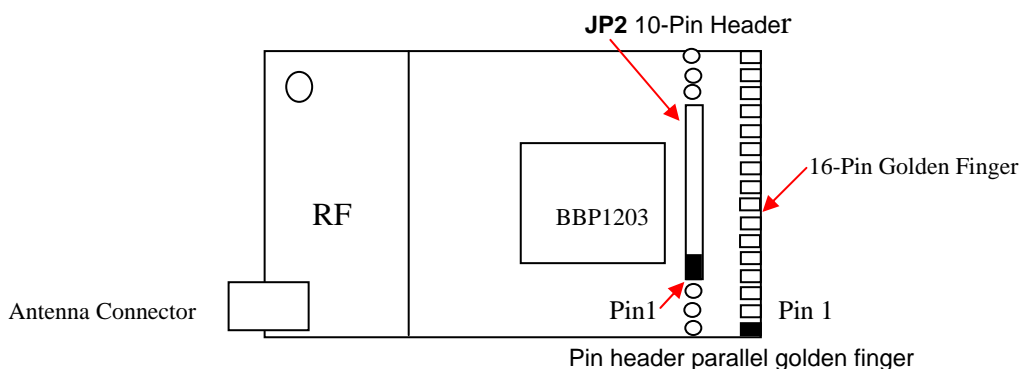

Figure 7

| Pin | Function | Input/Output | Level | Pin | Function | Input/Output | Level |
|-----|----------|--------------|-------|-----|----------|--------------|-------|
| 1 | TXD0 | Output | LVTTL | 2 | RXD0 | Input | LVTTL |
| 3 | PWR_IN | Input | 3.3V | 4 | GND | Ground | 0V |
| 5 | LED0 | In/Out | LVTTL | 6 | 1PPS | Output | LVTTL |
| 7 | TXD1 | Output | LVTTL | 8 | RXD1 | Input | LVTTL |
| 9 | VBAT | Input | 3.3V | 10 | ANT PWR | Input | |

The following is a functional description of the pins on the 16-pin interface connector.

Pin 1. TXD0: Serial port output # 1 (GPS navigation output)

Pin 2. RXD0: Serial port input # 1 (command input)

Pin 3. PWR_IN: Power supply input, regulated 3.3V

Pin 4. GND: Ground

Pin 5. LED0: Reserved I/O port 31 from CPU

Pin 6. 1PPS: 1-pulse-per-second output.

Pin 7. TXD1: Serial port output #2 (currently unused)

Pin 8. RXD1: Serial port input #2 (DGPS input)

Pin 9. VBAT: External backup battery charging input

Pin 10. ANT PWR: External active antenna power input

3.7 One-Pulse-Per-Second Output

The one-pulse-per-second output is provided for applications requiring precise timing measurements. The output pulse is 1usec in duration. The rising edge of the output pulse is accurate to +/-1usec with respect to the start of each GPS second. The accuracy of the one-pulse-per-second output is maintained only when the receiver has valid position fix.

3.8 RTCM Differential Data

By using differential GPS (DGPS) correction data in RTCM SC-104 format with message types of 1, 2, 3, and 9, position accuracy of less than 5 meters can be achieved. RXD1, pin-8 of the 10-pin Molex connector shown in figure 2, or pin-11 of the 16-pin header shown in figure 3, is used as the DGPS input. Differential correction is applied automatically when the correction data is received at 9600 baud.